

FEATURES

- * Voice length at
 - 8 KHz sampling is 32 seconds
 - 6 KHz sampling is 40 seconds
- * Silence compression to save memory
- * Eight trigger pins, TG1 to TG8 for 32 sections
- * SBT pin play-all or sequential play-all
- * 15 ms debounce time suitable for CDS
- * IRP interrupt pin stops playback at once
- * STP stop pulse generated at end of playback
- * BUSY signal for CPU control
- * Two LEDs flash at 3 Hz internal
- * 3.0V to 6V single power supply operation
- * Low standby current (<5 A at 3V)
- * Auto-power down
- * Built-in oscillator, D/A converter, EPROM
- * ADPCM data compression
- * Optional pop noise elimination function
- * COUT pin drives speaker with a transistor
- * Development tools support
- * VOUT1 and VOUT2 drives buzzer directly
- * Sampling rate determined by external resistor
- * Holdable and unholdable triggering option
- * Industrial temperature available

GENERAL DESCRIPTION

API840N is a high-quality voice synthesizer with a capacity of 32 to 40 seconds. A proprietary ADPCM algorithm is used. The audio message is stored in a 1024-Kbit on-chip EPROM.

The API840N eliminates the need of complicated circuitry in voice playback (Figure 1) but still achieves high voice quality. Sounds such as human speech, animal sounds, musical sounds, and even special sound effects can be synthesized. Devices can be cascaded to achieve longer voice duration (Figure 3). Two devices can be configured in parallel (Figure 4) in order to achieve signal mixing without an external mixer allowing speeches to be mixed with background music synthesis from two different chips.

The instant programming nature of the API840N allows a very short production turnaround time. There are no NRE charges that are usually required with conventional voice ROMs. Users now can apply a voice synthesis function as an additional feature to their products even when production volume is relatively small. It is also ideal for trial or engineering prototyping. As a result, the initial investment is minimal and the risk in the product development phase is reduced.

The API840N provides a wide voltage operating range from 3.0V to 6.0V. A pair of PWM output pins, VOUT1 and VOUT2 provide direct drive to a buzzer (Figure 2). Voice quality from a buzzer is comparable to speaker output and power consumption is much lower.

A current output pin, COUT, enables the device to drive a speaker with a low cost NPN transistor. No complex filtering or amplifier circuit is needed. An automatic ramp up/down function eliminates the undesired noise at the end of playback.

Up to 32 sections are accessible through TG1 to TG8. The SBT trigger pin can be programmed to playback all 32 sections or sequentially from section 1 to 32. An interrupt pin (IRP) and stop pulse (STP) or BUSY signals provide handshaking with microprocessors or other API840N devices. All trigger pins give 15 ms debounce time and is ideal for CDS applications as in Figure 6. Two LED drivers are available, flashing on and off at approximately 3Hz intervals (Figure 5). The internal voltage compensation oscillator requires only one external resistor. Different sampling frequencies are determined by the external oscillator resistor value.

BLOCK DIAGRAM

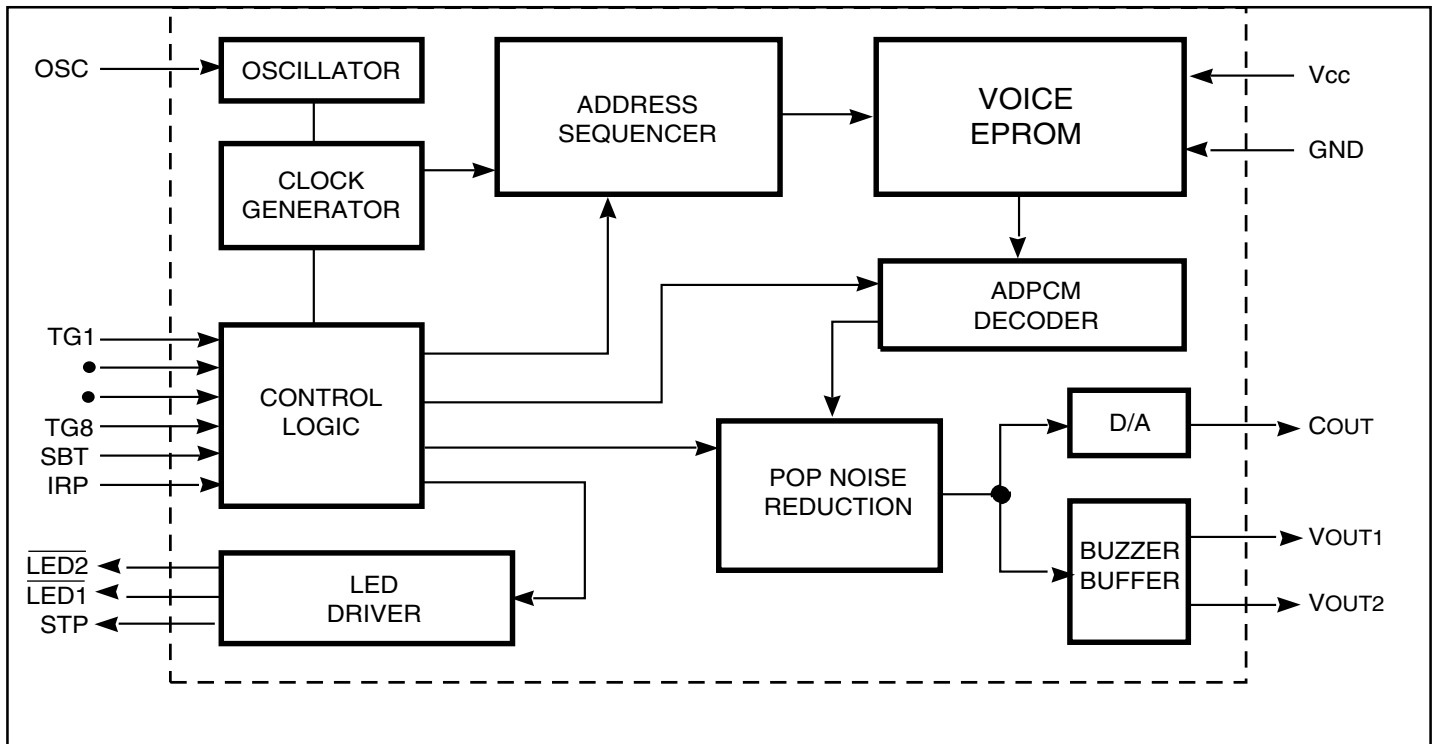

Programmable Options

The API840N provides different control functions for user specified applications. They include:

- * Non-sequential or Sequential Play-all
- * Unholdable or Holdable trigger
- * STOP or BUSY signal selection
- * Automatic ramp-up/ramp-down or no ramp-up/ramp-down

Silence Compression

If a particular sound sequence includes periods of silence, the API840N will automatically compress the silence to save memory space. This compression will not affect playback of the sound sequence.

ABSOLUTE MAXIMUM RATINGS⁽¹⁾

Symbol	Parameter	Value	Unit
V _{TERM}	Terminal Voltage with Respect to GND	-0.5 to +7.0	V
T _{BIAS}	Temperature Under Bias	-40 to +85	°C
T _{STG}	Storage Temperature	-55 to +125	°C

Notes:

1. Stress greater than those listed under ABSOLUTE MAXIMUM RATINGS may cause permanent damage to the device. This is a stress rating only and functional operation of the device at these or any other conditions above those indicated in the operational sections of this specification is not implied. Exposure to absolute maximum rating conditions for extended periods may affect reliability.

OPERATING RANGE

Range	Ambient Temp.	Vcc
Commercial	0°C to +70°C	3.0V to 6.0V
Industrial	-40 °C to +85°C	3.0V to 6.0V

SECTION TRIGGERING

TG1	TG2	TG3	TG4	TG5	TG6	TG7	TG8	Section
HIGH	NC	NC	NC	NC	NC	NC	NC	1
NC	HIGH	NC	NC	NC	NC	NC	NC	2
NC	NC	HIGH	NC	NC	NC	NC	NC	3
NC	NC	NC	HIGH	NC	NC	NC	NC	4
NC	NC	NC	NC	HIGH	NC	NC	NC	5
NC	NC	NC	NC	NC	HIGH	NC	NC	6
NC	NC	NC	NC	NC	NC	HIGH	NC	7
NC	NC	NC	NC	NC	NC	NC	HIGH	8
HIGH	HIGH	NC	NC	NC	NC	NC	NC	9
NC	HIGH	HIGH	NC	NC	NC	NC	NC	10
NC	NC	HIGH	HIGH	NC	NC	NC	NC	11
NC	NC	NC	HIGH	HIGH	NC	NC	NC	12
NC	NC	NC	NC	HIGH	HIGH	NC	NC	13
NC	NC	NC	NC	NC	HIGH	HIGH	NC	14
NC	NC	NC	NC	NC	NC	HIGH	HIGH	15
HIGH	NC	NC	NC	NC	NC	NC	HIGH	16
HIGH	HIGH	HIGH	NC	NC	NC	NC	NC	17
NC	HIGH	HIGH	HIGH	NC	NC	NC	NC	18
NC	NC	HIGH	HIGH	HIGH	NC	NC	NC	19
NC	NC	NC	HIGH	HIGH	HIGH	NC	NC	20
NC	NC	NC	NC	HIGH	HIGH	HIGH	NC	21
NC	NC	NC	NC	NC	HIGH	HIGH	HIGH	22
HIGH	NC	NC	NC	NC	NC	HIGH	HIGH	23
HIGH	HIGH	NC	NC	NC	NC	NC	HIGH	24
HIGH	HIGH	HIGH	HIGH	NC	NC	NC	NC	25
NC	HIGH	HIGH	HIGH	HIGH	NC	NC	NC	26
NC	NC	HIGH	HIGH	HIGH	HIGH	NC	NC	27
NC	NC	NC	HIGH	HIGH	HIGH	HIGH	NC	28
NC	NC	NC	NC	HIGH	HIGH	HIGH	HIGH	29
HIGH	NC	NC	NC	NC	HIGH	HIGH	HIGH	30
HIGH	HIGH	NC	NC	NC	NC	HIGH	HIGH	31
HIGH	HIGH	HIGH	NC	NC	NC	NC	HIGH	32

PIN DESCRIPTIONS

Name	I/O	Function
TG8	I	Trigger Switch 8, Internal Pull LOW, Active HIGH
LED 1	O	Drives First LED Flash at 3 Hz, Active LOW
VOUT1	O	PWM Audio Signal Output for Buzzer
VOUT2	O	Compliment PWM Audio Signal Output for Buzzer
GND	-	Power Ground
STP/BUSY	O	Generate 30 ms Pulse or Busy Signal After Voice Playback
LED 2	O	Drives Second LED Flash at 3 Hz, Active LOW
COU _T	O	Current Output from Internal DAC for Speaker Playback
OSC	I	Oscillator Resistor Pin to Control Sampling Frequency
TG5	I	Trigger Switch 5, Internal Pull LOW, Active HIGH
TG6	I	Trigger Switch 6, Internal Pull LOW, Active HIGH
V _{PP}	-	Program Power Supply, No Connect When Voice Playback
TG1	I	Trigger Switch 1, Internal Pull LOW, Active HIGH
TG2	I	Trigger Switch 2, Internal Pull LOW, Active HIGH
V _{CC}	-	Positive Power Supply
TG3	I	Trigger Switch 3, Internal Pull LOW, Active HIGH
TG4	I	Trigger Switch 4, Internal Pull LOW, Active HIGH
SBT	I	One Key or Sequential Trigger, Internal Pull LOW, Active HIGH
IRP	I	Interrupt to Stop Playback, Internal Pull LOW, Active HIGH
TG7	I	Trigger Switch 7, Internal Pull LOW, Active HIGH

PIN CONFIGURATION

20-Pin 300-mil PDIP

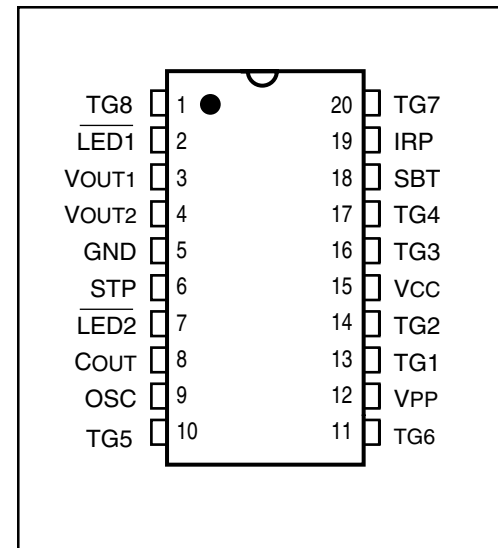

Note:

1. The following pins are used to program data into the memory on the chip: pins 5, 6, 7, 9, 12, 15, 18 and 19.

BONDING DIAGRAM

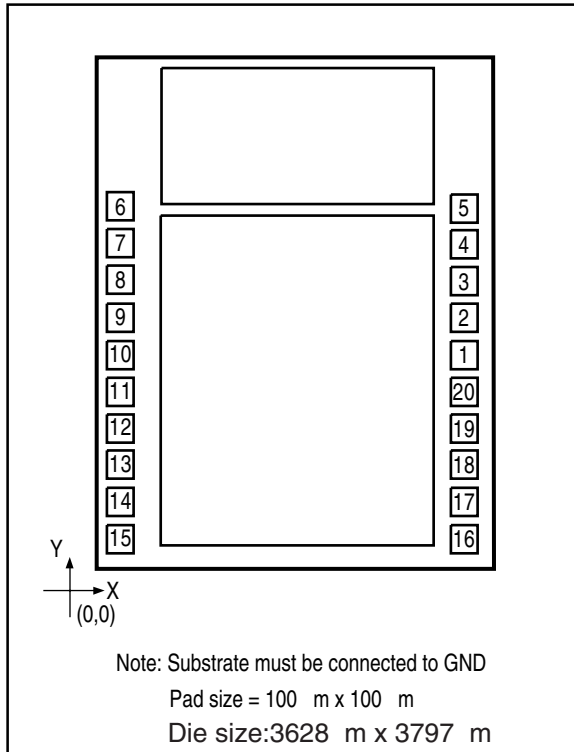

BONDING PARAMETERS

Pin	Name	X	Y
1	TG8	3451.9	1599.7
2	LED1	3451.9	1861.0
3	VOUT1	3451.9	2147.6
4	VOUT2	3451.9	2444.5
5	GND	3368.10	2803.35
6	STP	137.18	2795.93
7	LED2	100.4	2486.3
8	COU	100.4	2245.0
9	OSC	100.4	1790.0
10	TG5	100.4	1469.5
11	TG6	100.4	1230.0
12	VPP	100.4	989.6
13	TG1	100.4	662.3
14	TG2	100.4	422.7
15	VCC	187.05	113.78
16	TG3	3372.5	141.8
17	TG4	3451.9	581.5
18	SBT	3451.9	836.0
19	IRP	3451.9	1090.6
20	TG7	3451.94	1345.13

DC CHARACTERISTICS

Symbol	Parameter Description	Condition	Min.	Typ.	Max.	Unit
VCC	Operating Voltage		3.0	4.5	6.0	V
ISB	Standby Current	VCC = 3.0V, I/O Open	-	1	5	A
IOp	Operating Current	VCC = 3.0V, I/O Open	-	-	100	A
VIH	Input HIGH Voltage	VCC = 3.0V	2.5	3.0	3.5	V
VIL	Input LOW Voltage	VCC = 3.0V	-0.3	0	0.3	V
IOH	VOUT LOW O/P Current	VCC = 3.0V, VOUT = 0V	-	-12	-	mA
IOl	VOUT HIGH O/P Current	VCC = 3.0V, VOUT = 3.0V	-	12	-	mA
ICO	COU O/P Current	VCC = 3.0V, VCOU = 0.7V	-	-2	-	mA
ISTPH	STP LOW O/P Current	VCC = 3.0V, VSTP = 0V	-	-5	-	mA
TSTPL	STP HIGH O/P Current	VCC = 3.0V, VSTP = 3.0V	-	5	-	mA
ILED	Output Current LED	VCC = 3.0V - 6.0V	6	8	10	mA
F/F	Frequency Stability	$\frac{F_{osc}(3V) - F_{osc}(3.5V)}{F_{osc}(3V)}$	-	-	5	%

TIMING DIAGRAM

PULSE TRIGGERED.

a. Trigger is shorter than a phrase output

b. Trigger is longer than a phrase output

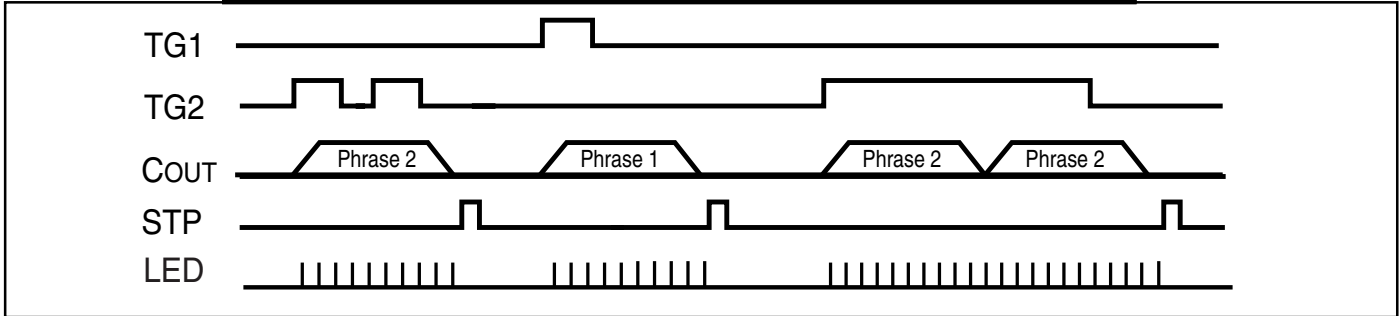

LEVEL TRIGGERED

a. Trigger is shorter than a phrase output

b. Trigger is longer than a phrase output

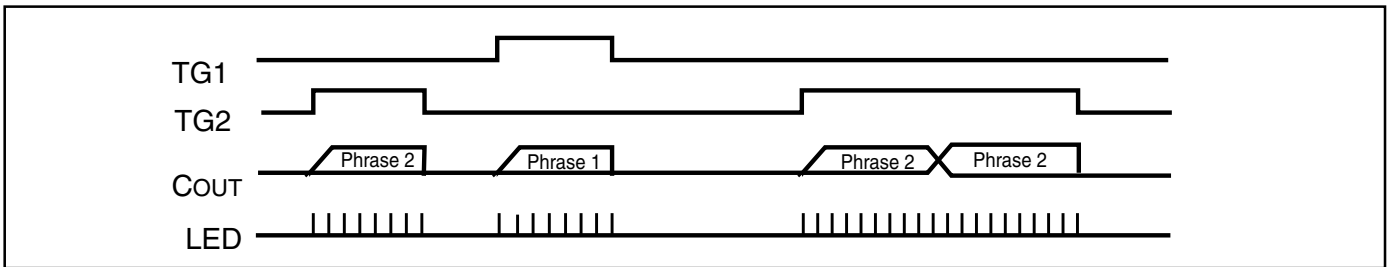

SINGLE BUTTON TRIGGER, NON-SEQUENTIAL PLAY-ALL (SBT)

a. Pulse Triggered

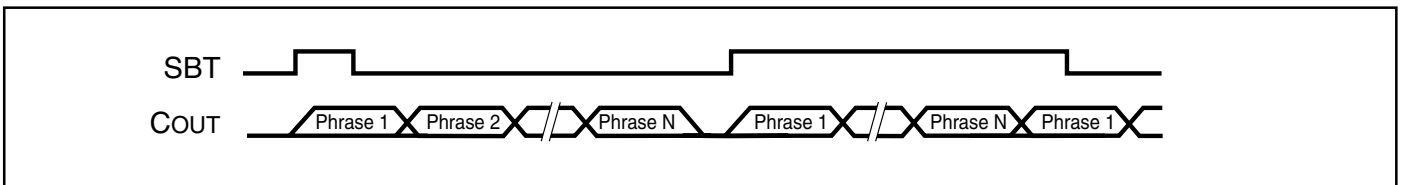

b. Level Triggered

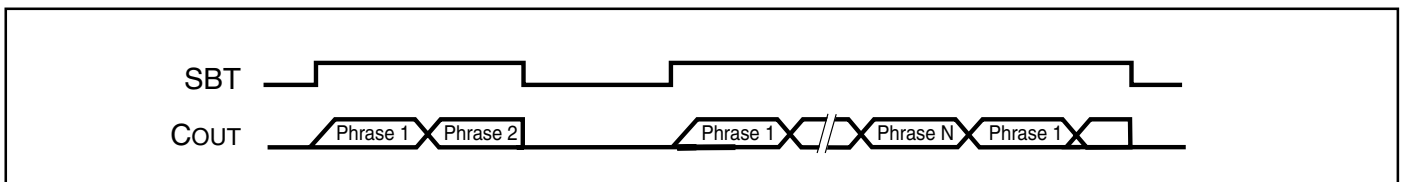

SINGLE BUTTON TRIGGER, SEQUENTIAL (SBT)

a. Pulse Triggered

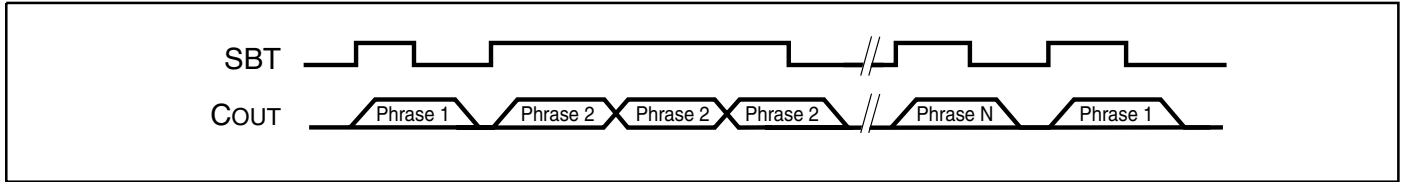

b. Level Triggered

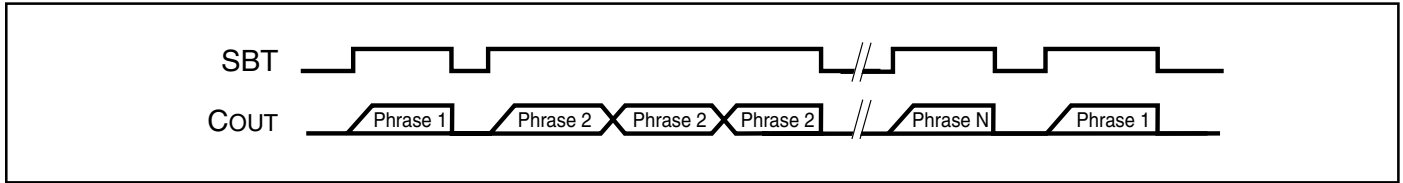

APPLICATION CIRCUITS

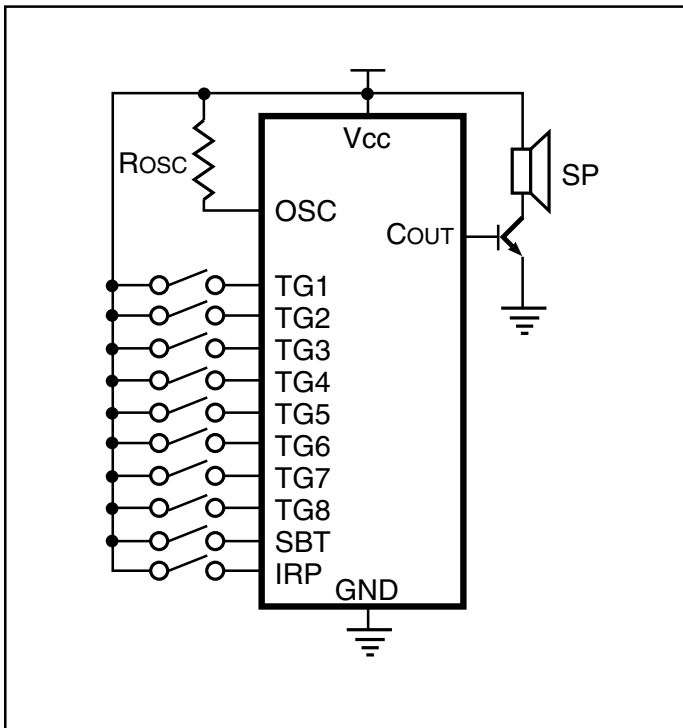

Figure 1. Typical Application with Speaker

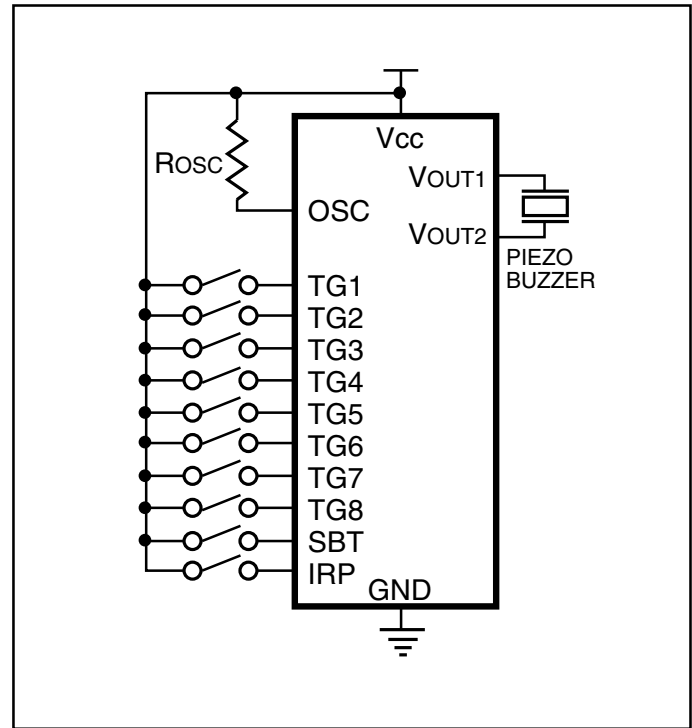

Figure 2. Typical Application with Piezo Buzzer

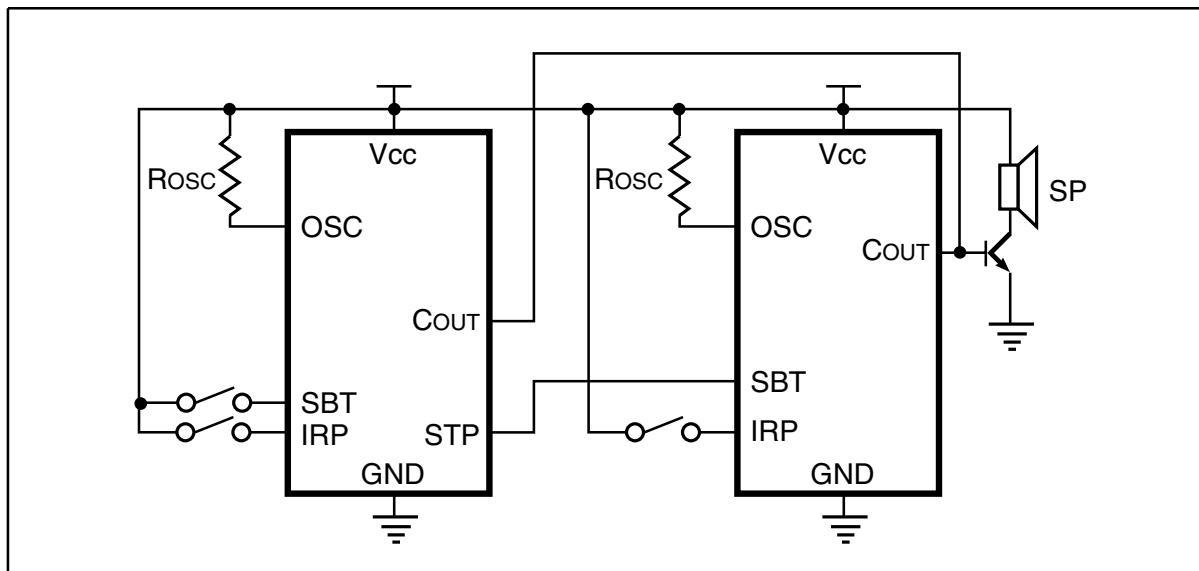

Figure 3. Cascade Application

APPLICATION CIRCUITS

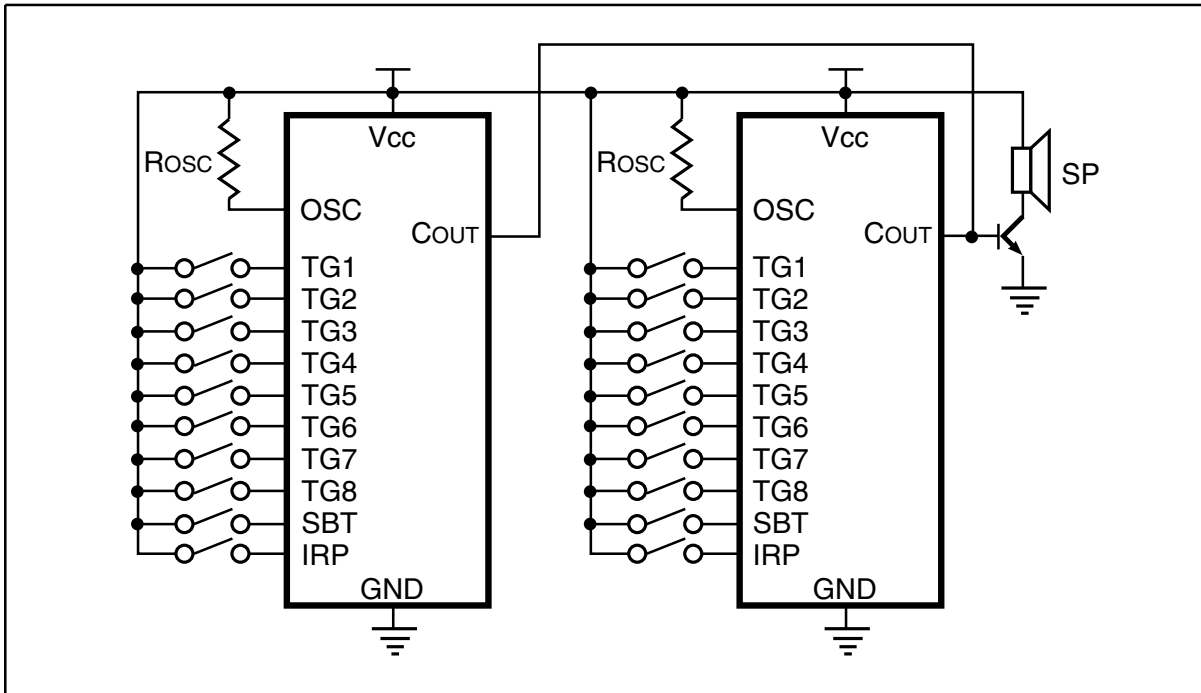

Figure 4. Parallel Application
(Mixing two speeches or speech with background music)

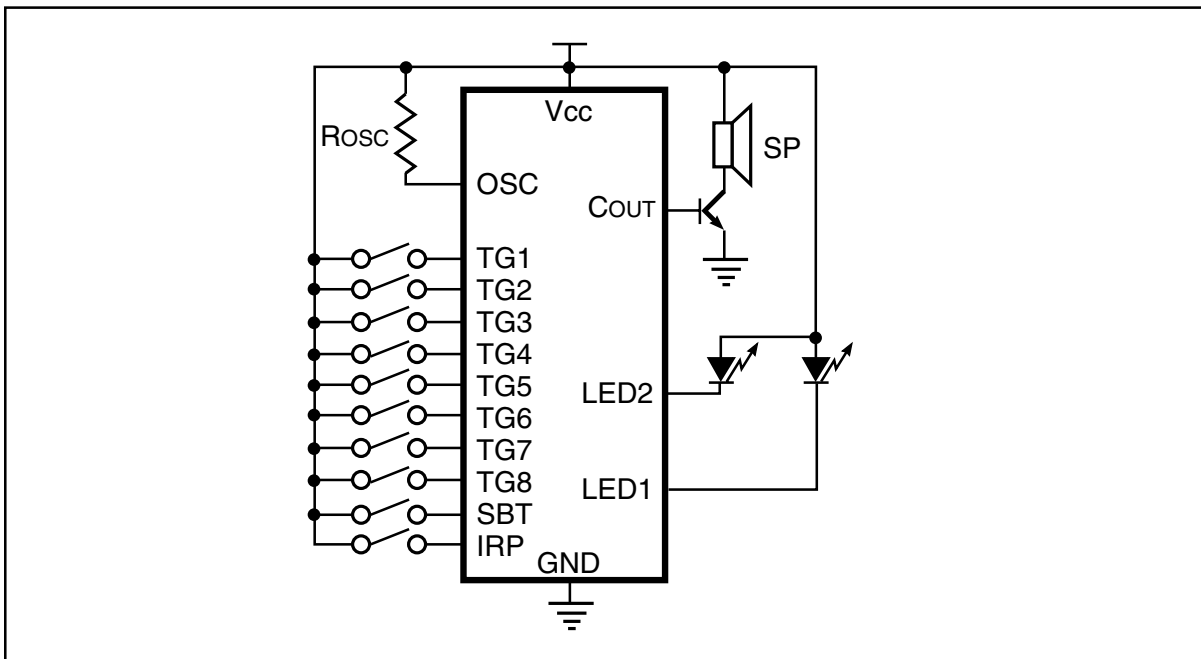

Figure 5. LED Application

APPLICATION CIRCUITS

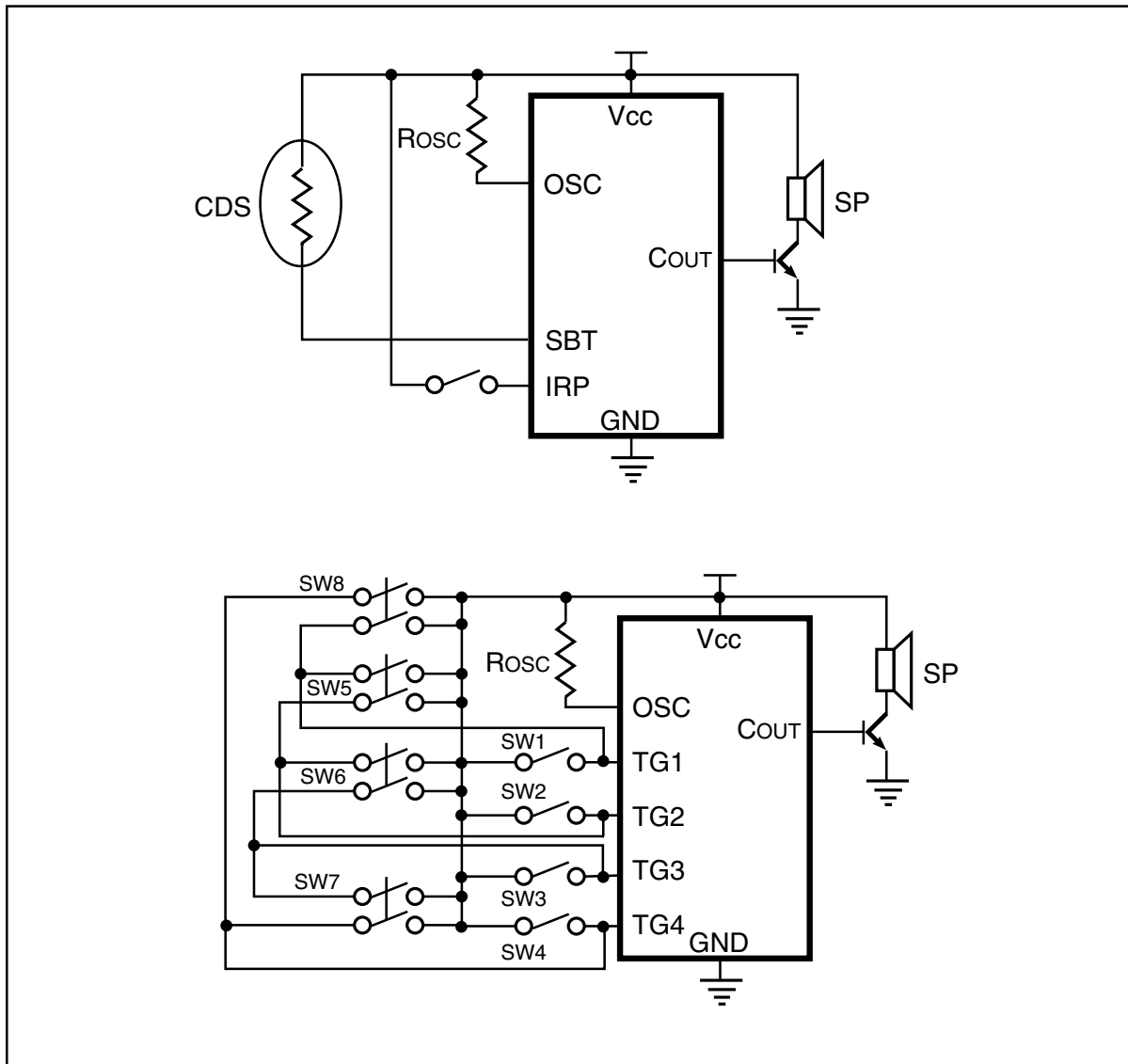

Figure 6. CDS Application and Additional Trigger

Notes:

The following are typical values:

1. $R_{osc} = 2.0 \text{ MW}$.
2. B for N (NPN transistor) > 130 .
3. SP = 8W. 1/4W.
4. Piezo buzzer resonant frequency = 1 KHz.